

CHT-OPA

Revision: 01.00
May. 29, 2008

High-Temperature General-Purpose Quad Operational Amplifier

General Description

The CHT-OPA is a general-purpose quad operational amplifier for applications over the temperature range from -55 to 225°C. This circuit is fabricated using an CMOS SOI process, assuring latchup-free operation for all operation conditions.

The CHT-OPA can operate with both single and symmetrical power supplies. The supply voltages range goes from 4.5 to 20V.

Parts are still operational up to 300°C with derated performance (see Typical Performance Characteristics section).

The CHT-OPA uses internal metal lines presenting extremely high immunity to electromigration, improving product lifetime.

Features

- Qualified from -55 to +225°C (Tj)
- Operational up to +300°C (Tj)
- 4.5 to 20V supply voltages
- Single or symmetrical supply operation
- Latchup-free at any supply and temperature condition
- Available in DIL14 hermetic ceramic standard package
- Improved internal metallization for extended reliability

Applications

- Well logging, Automotive, Aeronautics & Aerospace
- Harsh Environments

Package Configurations¹

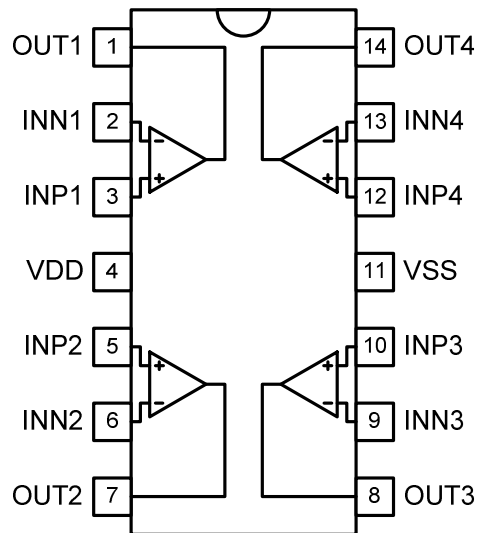

Ceramic DIL14 (Top view)

¹ Other packages available upon request.

Absolute Maximum Ratings

Supply Voltage VDD to VSS -0.5 to 25V
 Voltage on any Pin to VSS -0.5 to V_{DD}+0.5V

ESD Rating (expected)

Human Body Model 1kV

Operating Conditions

Supply Voltage VDD to VSS 4.5V to 20V
 Junction temperature -55°C to +225°C

Operation up to +300°C (T_j) can be obtained with some derating on performance.

DC Electrical Characteristics

Unless otherwise stated: VDD=10V, VSS=0V, T_j=25°C. **Bold underlined** values indicate values over the whole temperature range (-55°C < T_j < +225°C).

Parameter	Condition	Min	Typ	Max	Units
Supply voltage VDD-VSS		4.5		20	V
Supply current (full package) I_{DD}	T _j =25°C			1.7	mA
	T _j =-55 to 225°C			<u>2.2</u>	
Output voltage swing V_o	R _L =2kΩ, THD ¹ =1%	0.15		VDD-0.18	V
	R _L =∞, THD=0.1%	0.03		VDD-0.02	
Output current ^{2,3} I_o	T _j =-55 to 225°C			<u>±15</u>	mA
Common mode input range V_{CM}	T _j =225°C	2.0		VDD-0.1	V
	T _j =-55°C	1.5		VDD-0.2	
Input offset voltage ⁴ V_{IOFF}	T _j =25°C		<±2.5	±8	mV
Input offset drift ³ TC_{VIOFF}	T _j =25°C		<±5	±15	μV/°C
Input bias current ⁵ I_B	T _j =-55 to 225°C			<u>±10</u>	nA
Input offset current ⁴ I_{OFF}	T _j =25°C			±0.01	nA
	T _j =225°C			±10	

¹ Total Harmonic Distortion.

² Source or sink.

³ Output current is not internally limited. Value given indicate the maximum recommended conditions.

⁴ The absolute value of the input offset voltage, |V_{IOFF}|, decreases as temperature increases. TC_{VIOFF} must be used so that |V_{IOFF}| decreases with temperature, i.e. TC_{VIOFF} has opposite sign than V_{IOFF}.

⁵ Due to ESD structures. Under full characterization.

AC Electrical Characteristics

Unless otherwise stated: VDD=10V, VSS=0V, $T_j=25^\circ\text{C}$. **Bold underlined** values indicate values over the whole temperature range ($-55^\circ\text{C} < T_j < +225^\circ\text{C}$).

Parameter	Condition	Min	Typ	Max	Units
DC gain A_o	RL=2k Ω , $T_j=25^\circ\text{C}$	90	100		dB
	RL=2k Ω , $T_j=225^\circ\text{C}$	80	87		
Gain-bandwidth product GBW	RL=2k Ω , CL=30pF	<u>1.3</u>	<u>1.5</u>		MHz
Common mode rejection ratio CMRR	DC to 1kHz	<u>86</u>			dB
Power supply rejection ratio PSRR	Positive or negative. DC to 100Hz	<u>78</u>			dB
Slew rate SR	RL=2k Ω , CL=30pF $T_j=25^\circ\text{C}$	1.0	1.2		V/ μsec
	RL=2k Ω , CL=30pF $T_j=225^\circ\text{C}$	1.6	1.7		
Phase margin Φ_M	RL=2k Ω , CL=30pF	<u>50</u>	<u>>60</u>		Degree
Input noise spectral density	F=1Hz		11.0		$\mu\text{V}/\sqrt{\text{Hz}}$
	F=100Hz		1.2		
	F=1kHz		0.43		
	F=10kHz		0.19		
Integrated input noise e_n	DC to 10Hz, $T_j=-55$ to 225°C		25		μV_{RMS}

Typical Performance Characteristics

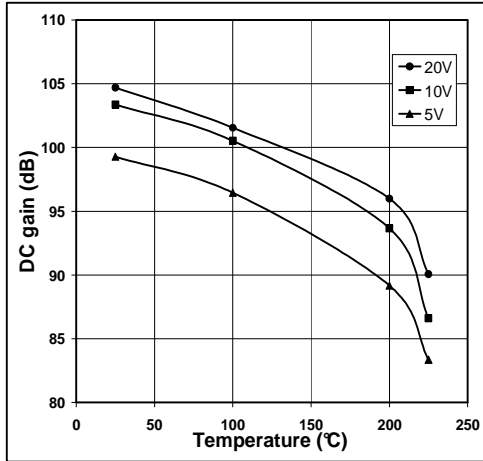

DC Gain vs. Temperature for $V_{DD} = 5/10/20V$

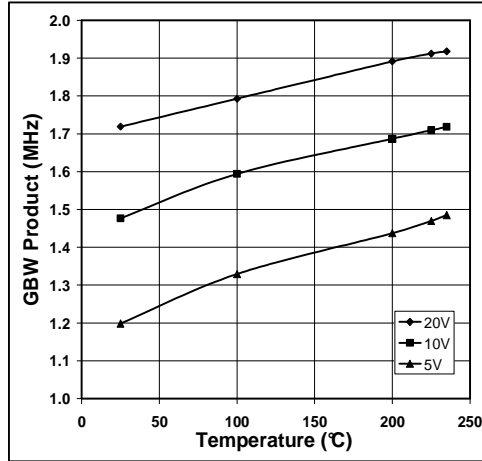

GBW vs. Temperature for $V_{DD} = 5/10/20V$

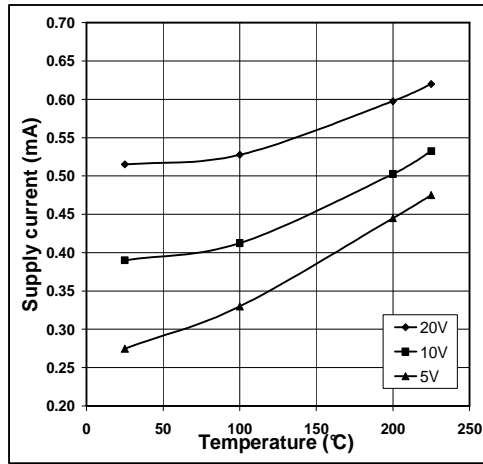

Current consumption per amplifier vs. Temperature for $V_{DD} = 5/10/20V$

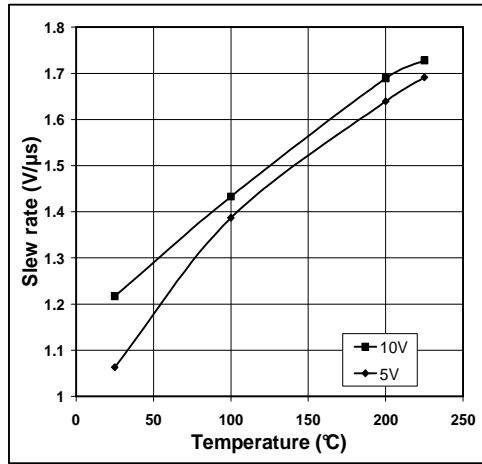

Slew Rate vs. Temperature for $V_{DD} = 5/10V$

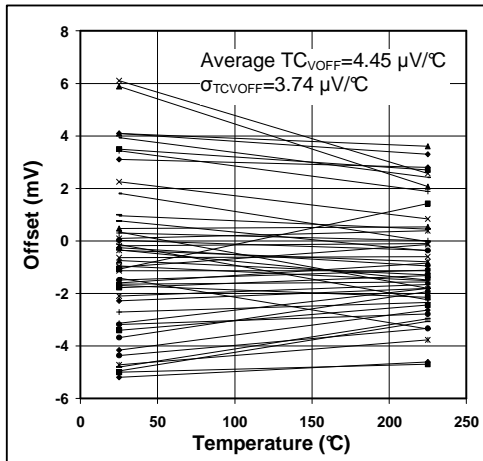

Offset voltage vs. Temperature

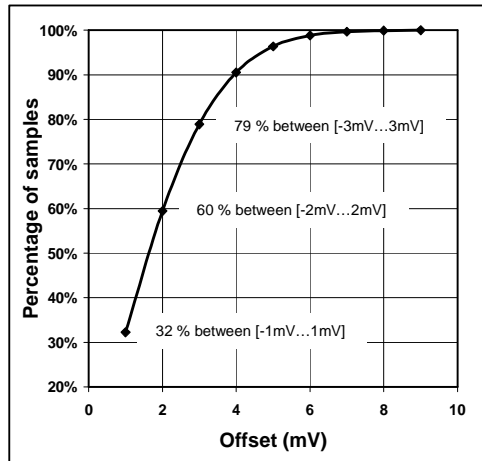

Sample size vs. Offset voltage

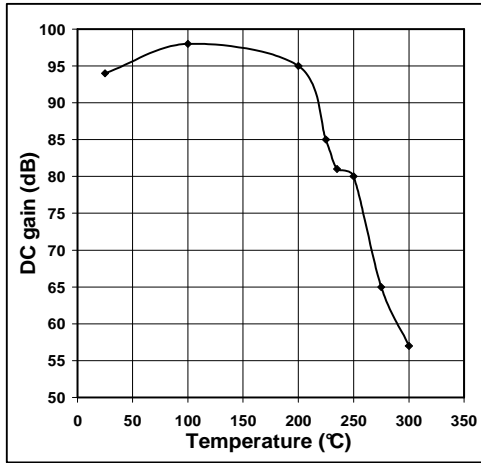

DC Gain vs. Temperature for $V_{DD} = 10V$. Typical

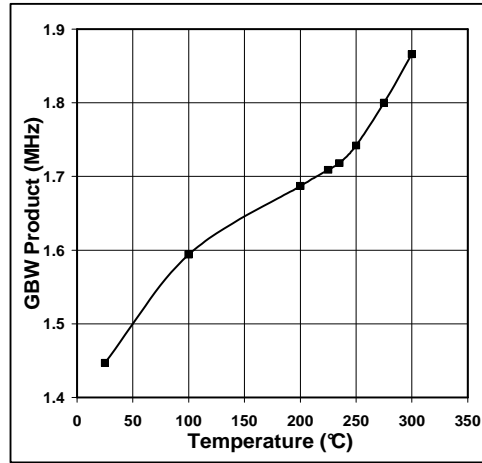

GBW vs. Temperature for $V_{DD} = 10V$. Typical

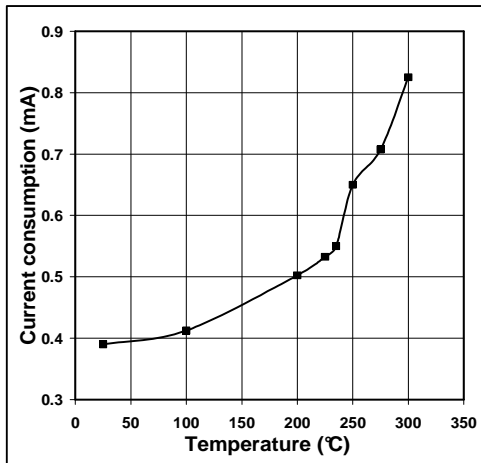

Current consumption per aplifier vs. Temperature for $V_{DD} = 10V$. Typical

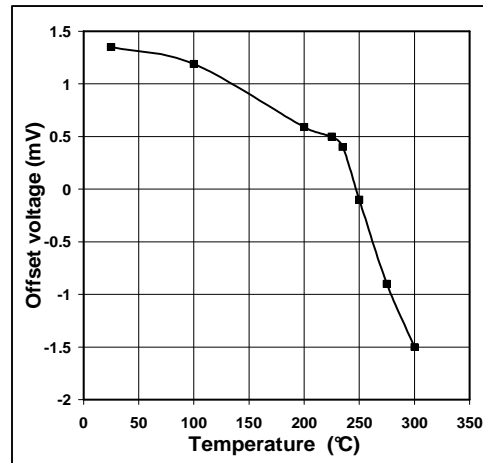

Offset voltage vs. Temperature. Typical

Circuit Functionality

Operating conditions

The CHT-OPA has been qualified to operate with supply voltages ranging from 4.5V to 20V and temperatures from -55°C to 225°C. Device characteristics vary smoothly outside the qualification temperature range. Operation down to cryogenic temperatures has been achieved. On the other side of the temperature scale, operation up to 300°C has also been reached.

The CHT-OPA has been conceived to operate in closed loop configuration under linear regime. This limitation only applies for supply voltages above 5.5V. When operating with supply voltages above 5.5V, internal circuitry prevents exceeding "Safe Operating Area" conditions inside the circuit. Nevertheless, continuous or repetitive

operation outside linear regime could permanently damage the part.

For supply voltages below 5.5V, no limitation on the operation regime exists and the part can even be used as comparator.

Specific Operating Conditions

The CHT-OPA presents slightly different positive and negative slewing values. This makes that when a square wave is used as input signal, the output presents an additional DC offset due to the slight change of the output duty cycle.

Additionally, for square input signals which frequencies above 10kHz, the circuit presents an output DC offset which increases with the input frequency. At 30kHz, the input referred offset increases by about 20mV.

Ordering Information

Ordering Reference	Package	Temperature Range	Marking
CHT-OPA-DIL14-T	Ceramic DIL14	-55°C to +225°C	CHT-OPA

Contact & Ordering

Headquarters and contact EMEA:

CISSOID S.A.
Chemin du Cyclotron,6 – 1348 Louvain-La-Neuve – Belgium
T: +32 10 48 92 10
F: +32 10 48 92 19
Email: sales@cissoid.com

Distributor for USA and Mexico:

Trendsetter Electronics, Inc.
1910 Sam Bass Road – Round Rock – TX 78681 – USA
T: +1 800 310 3050 or +1 512 310 8858
F: +1 800 681 5010 or +1 512 310 8892
Email: sales@trendsetter.com

Sales Representatives:

USA – Oklahoma, Arkansas, Texas and Louisiana:
NW Sales, LP
6031 W. I-20, Suite 242 – Arlington, TX 76017 – USA
T: +1 817.483.5676
F: +1 817 860-1633
John Rymell – Email: john@nwsaleslp.com or amber@nwsaleslp.com

USA – All other States:

Trendsetter Electronics, Inc.
1910 Sam Bass Road – Round Rock – TX 78681 – USA
T: +1 800 310 3050 or +1 512 310 8858
F: +1 800 681 5010 or +1 512 310 8892
Email: sales@trendsetter.com

Disclaimer

Neither CISSOID, nor any of its directors, employees or affiliates make any representations or extend any warranties of any kind, either express or implied, including but not limited to warranties of merchantability, fitness for a particular purpose, and the absence of latent or other defects, whether or not discoverable. In no event shall CISSOID, its directors, employees and affiliates be liable for direct, indirect, special, incidental or consequential damages of any kind arising out of the use of its circuits and their documentation, even if they have been advised of the possibility of such a damage. The circuits are provided "as is". CISSOID has no obligation to provide maintenance, support, updates, or modifications.