

CMT-7486 DATASHEET

Revision: 1.5
15-Dec-23
(Last Modified Date)

High-Temperature, Quad 2-Inputs XOR Gate

General Description

The CMT-7486 contains four independent 2-inputs XOR gates, performing the Boolean function :

$$Y = A \oplus B = A \cdot \bar{B} + \bar{A} \cdot B$$

The CMT-7486 can operate with supply voltages from 3.3 to 5V ($\pm 10\%$).

Features

- Qualified from -55 to +175°C (Tj)
- 3.3 to 5V ($\pm 10\%$) supply voltages
- Latchup-free at any supply and temperature condition
- Validated at 175°C for 20000 hours (and still on-going)
- Available in plastic SOIC16 standard package

Applications

- Well logging,
- Automotive, Aeronautics & Aerospace
- Harsh Environments

Package and Pin Configuration

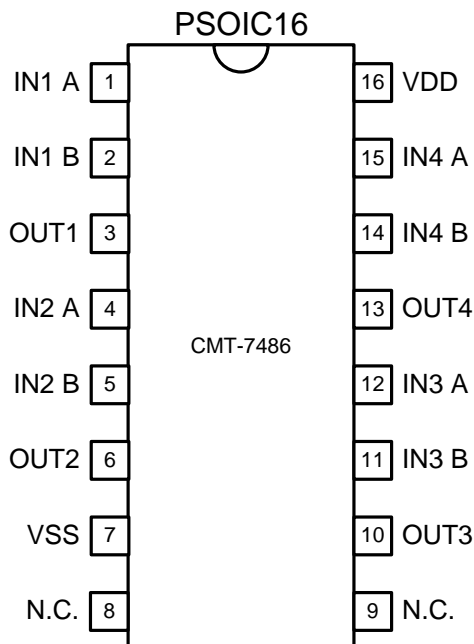

Pin	Symbol	Description
1	IN1 A	Input A of the XOR gate number 1
2	IN1 B	Input B of the XOR gate number 1
3	OUT1	Output of the XOR gate number 1
4	IN2 A	Input A of the XOR gate number 2
5	IN2 B	Input B of the XOR gate number 2
6	OUT2	Output of the XOR gate number 2
7	VSS	Circuit core ground terminal.
8	N.C.	No connected terminal.
9	N.C.	No connected terminal.
10	OUT3	Output of the XOR gate number 3
11	IN3 B	Input B of the XOR gate number 3
12	IN3 A	Input A of the XOR gate number 3
13	OUT4	Output of the XOR gate number 4
14	IN4 B	Input B of the XOR gate number 4
15	IN4 A	Input A of the XOR gate number 4
16	VDD	Circuit core power supply terminal.

Function Table

INPUT		OUTPUT
A	B	Y
L	L	L
L	H	H
H	L	H
H	H	L

Function and Logical Diagrams

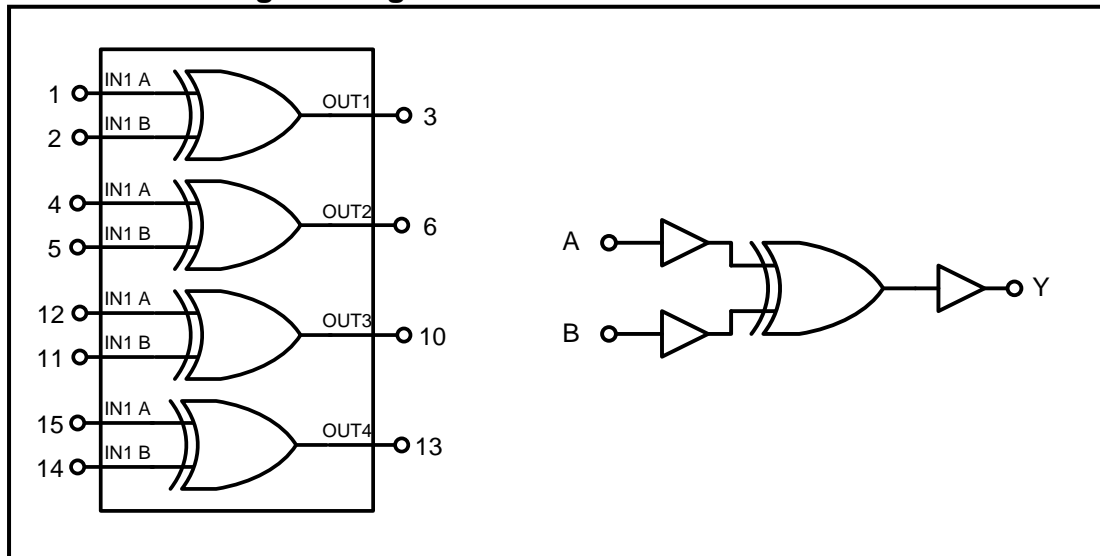

Figure 1. CMT-7486: simplified block diagram.

Absolute Maximum Ratings

Supply Voltage V_{DD} to GND -0.5 to 6.0V
Voltage on any Pin to GND -0.5 to $V_{DD}+0.5V$

Operating Conditions

Supply Voltage V_{DD} to GND 3.3V to 5V ($\pm 10\%$)
Junction temperature -55°C to +175°C

ESD Rating (expected)

Human Body Model 1kV

DC Electrical Characteristics

Unless otherwise stated: $T_j=25^\circ\text{C}$. **Bold underlined** figures indicate values valid over the whole temperature range ($-55^\circ\text{C} < T_j < +175^\circ\text{C}$).

Parameter	Condition	Min	Typ	Max	Units
Supply voltage V_{DD}		3.3	5V		V
Quiescent current I_{DD}	$V_{DD} = 3.3V, T_j = -55^\circ\text{C}$			4	nA
	$V_{DD} = 5V, T_j = -55^\circ\text{C}$			6	
	$V_{DD} = 3.3V, T_j = 175^\circ\text{C}$			<u>685</u>	
	$V_{DD} = 5V, T_j = 175^\circ\text{C}$			<u>690</u>	
Minimum HIGH level output voltage V_{OH}	$V_{DD} = 3.3V, I_{OH} < 2\text{mA}$ (source)	<u>2.46</u>			V
	$V_{DD} = 5V, I_{OH} < 4\text{mA}$ (source)	<u>4.47</u>			
Maximum LOW level output voltage V_{OL}	$V_{DD} = 3.3V, I_{OL} < 2\text{mA}$ (sink)			<u>0.41</u>	V
	$V_{DD} = 5V, I_{OL} < 4\text{mA}$ (sink)			<u>0.59</u>	
Minimum HIGH level input voltage V_{IH}	$V_{DD} = 3.3V$	<u>2.2</u>			V
	$V_{DD} = 5V$	<u>3.3</u>			
Maximum LOW level input voltage V_{IL}	$V_{DD} = 3.3V$			<u>1.5</u>	V
	$V_{DD} = 5V$			<u>2.2</u>	

AC Electrical Characteristics

Unless otherwise stated: VDD=5V, $T_j=25^\circ\text{C}$. **Bold underlined** figures indicate values valid over the whole temperature range ($-55^\circ\text{C} < T_j < +175^\circ\text{C}$).

Parameter	Condition	Temperature	Min	Typ	Max	Units
Propagation delay time from A or B to Y ¹ t_{PHL}	$C_L=50\text{pF}$	$T_j=-55^\circ\text{C}$		7.3	9.6	ns
		$T_j=25^\circ\text{C}$		8.9	12.2	
		$T_j=175^\circ\text{C}$		12.3	17.4	
Propagation delay time from A or B to Y t_{PLH}	$C_L=50\text{pF}$	$T_j=-55^\circ\text{C}$		7.1	9.9	ns
		$T_j=25^\circ\text{C}$		9	12.7	
		$T_j=175^\circ\text{C}$		12.4	18	
Output transition time High to Low t_{THL}	$C_L=50\text{pF}$	$T_j=-55^\circ\text{C}$		6.3	8.2	ns
		$T_j=25^\circ\text{C}$		7.8	10.3	
		$T_j=175^\circ\text{C}$		11.2	15.2	
Output transition time Low to High t_{TLH}	$C_L=50\text{pF}$	$T_j=-55^\circ\text{C}$		5.7	8	ns
		$T_j=25^\circ\text{C}$		7.5	10.4	
		$T_j=175^\circ\text{C}$		10.5	14.5	

¹ Input A is 1% to 2% faster than input B.

AC Electrical Characteristics (cntd)

Unless otherwise stated: $V_{DD}=3.3V$, $T_j=25^\circ C$. **Bold underlined** figures indicate values valid over the whole temperature range ($-55^\circ C < T_j < +175^\circ C$).

Parameter	Condition	Temperature	Min	Typ	Max	Units
Propagation delay time from A or B to Y t_{PHL}	$C_L=50pF$	$T_j=-55^\circ C$		14.1	22.4	ns
		$T_j=25^\circ C$		16.9	27	
		$T_j=175^\circ C$		22.3	35	
Propagation delay time from A or B to Y t_{PLH}	$C_L=50pF$	$T_j=-55^\circ C$		13.8	21.9	ns
		$T_j=25^\circ C$		16.9	27.6	
		$T_j=175^\circ C$		22	35.5	
Output transition time High to Low t_{THL}	$C_L=50pF$	$T_j=-55^\circ C$		12.2	19.7	ns
		$T_j=25^\circ C$		16.7	25.1	
		$T_j=175^\circ C$		21.4	33.5	
Output transition time Low to High t_{TLH}	$C_L=50pF$	$T_j=-55^\circ C$		10.7	18	ns
		$T_j=25^\circ C$		12.7	21.4	
		$T_j=175^\circ C$		16.6	25.8	

AC Waveforms

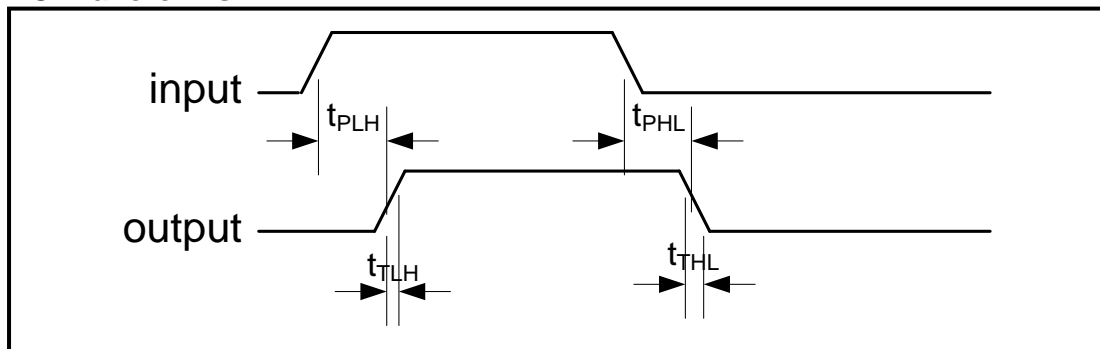
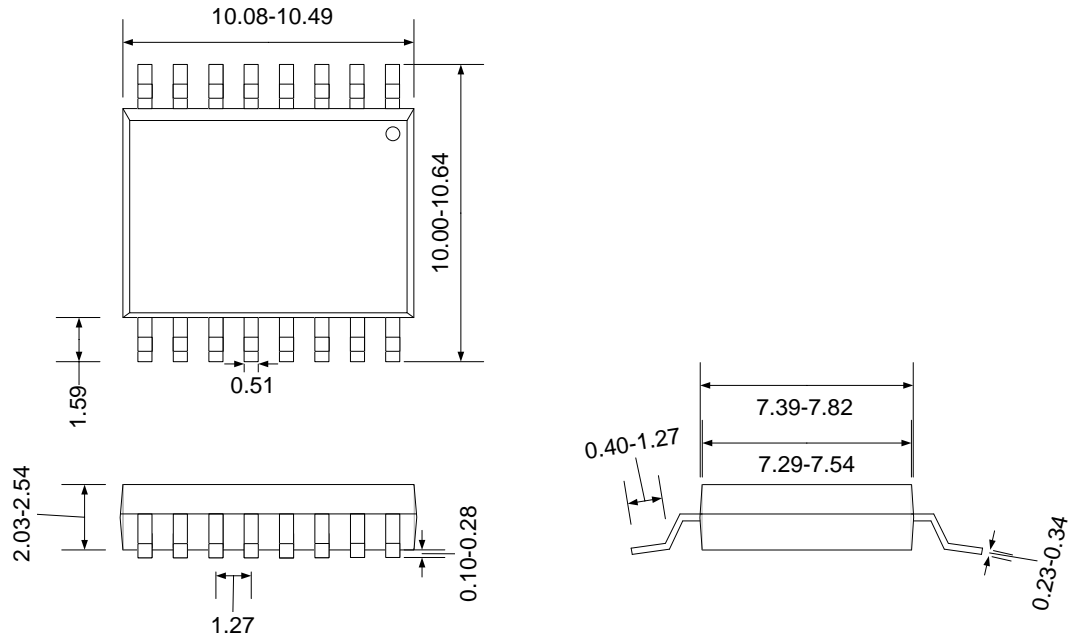

Figure 2. AC Waveforms

Ordering Information

Ordering Reference	Package	Temperature Range	Marking
CMT-7486-PSOIC16-T	Plastic SOIC16	-55°C to +175°C	CMT-7486

Package Dimensions



Drawing PSOIC16 (mm +/- 10%)

Contact & Ordering

CISOID S.A.

Headquarters and contact EMEA:	CISOID S.A. – Rue Francqui, 11 – 1435 Mont Saint Guibert - Belgium T : +32 10 48 92 10 - F: +32 10 88 98 75 Email: sales@cissoid.com
Sales Representatives:	Visit our website: http://www.cissoid.com

Disclaimer

Neither CISOID, nor any of its directors, employees or affiliates make any representations or extend any warranties of any kind, either express or implied, including but not limited to warranties of merchantability, fitness for a particular purpose, and the absence of latent or other defects, whether or not discoverable. In no event shall CISOID, its directors, employees and affiliates be liable for direct, indirect, special, incidental or consequential damages of any kind arising out of the use of its circuits and their documentation, even if they have been advised of the possibility of such a damage. The circuits are provided "as is". CISOID has no obligation to provide maintenance, support, updates, or modifications.