

CMT-7404 DATASHEET

Revision: 1.5
10-Dec-23
(Last Modified Date)

High-Temperature, Hex Inverter

General Description

The CMT-7404 contains six independent inverter, performing the Boolean function :

$$Y = \overline{A}$$

This circuit is fabricated using a CMOS SOI process, assuring latchup-free operation for all supply and temperature conditions.

The CMT-7404 can operate with supply voltages from 3.3 to 5V ($\pm 10\%$).

The CMT-7404 uses internal metal lines presenting extremely high immunity to electromigration, improving product lifetime by a factor of 10, compared to the case where aluminum metallization is used.

Features

- Qualified from -55 to +175°C (Tj)
- 3.3 to 5V ($\pm 10\%$) supply voltages
- Latchup-free at any supply and temperature condition
- Validated at 175°C for 20000 hours (and still on-going)
- Available in plastic SOIC16 standard package
- Improved internal metallization for extended reliability

Applications

- Well logging,
- Automotive, Aeronautics & Aerospace
- Harsh Environments

Package and Pin Configuration

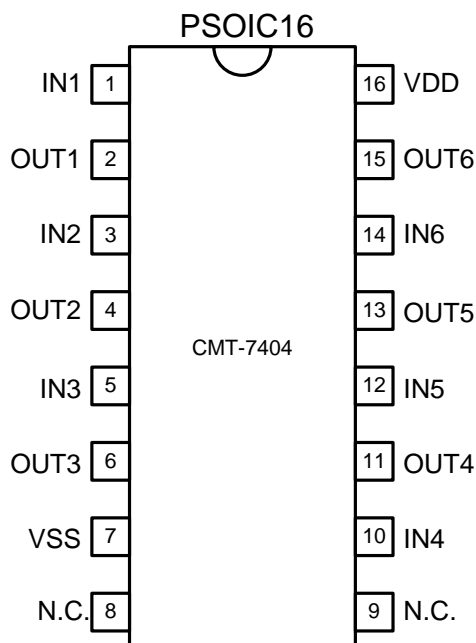

Pin	Symbol	Description
1	IN1	Input of inverter number 1
2	OUT1	Output of inverter number 1
3	IN2	Input of inverter number 2
4	OUT2	Output of inverter number 2
5	IN3	Input of inverter number 3
6	OUT3	Output of inverter number 3
7	GND	Circuit core ground terminal.
8	N.C.	No connected terminal
9	N.C.	No connected terminal
10	IN4	Input of inverter number 4
11	OUT4	Output of inverter number 4
12	IN5	Input of inverter number 5
13	OUT5	Output of inverter number 5
14	IN6	Input of inverter number 6
15	OUT6	Output of inverter number 6
16	VDD	Circuit core power supply terminal.

Function Table

INPUT	OUTPUT
A	Y
L	H
H	L

Function and Logical Diagrams

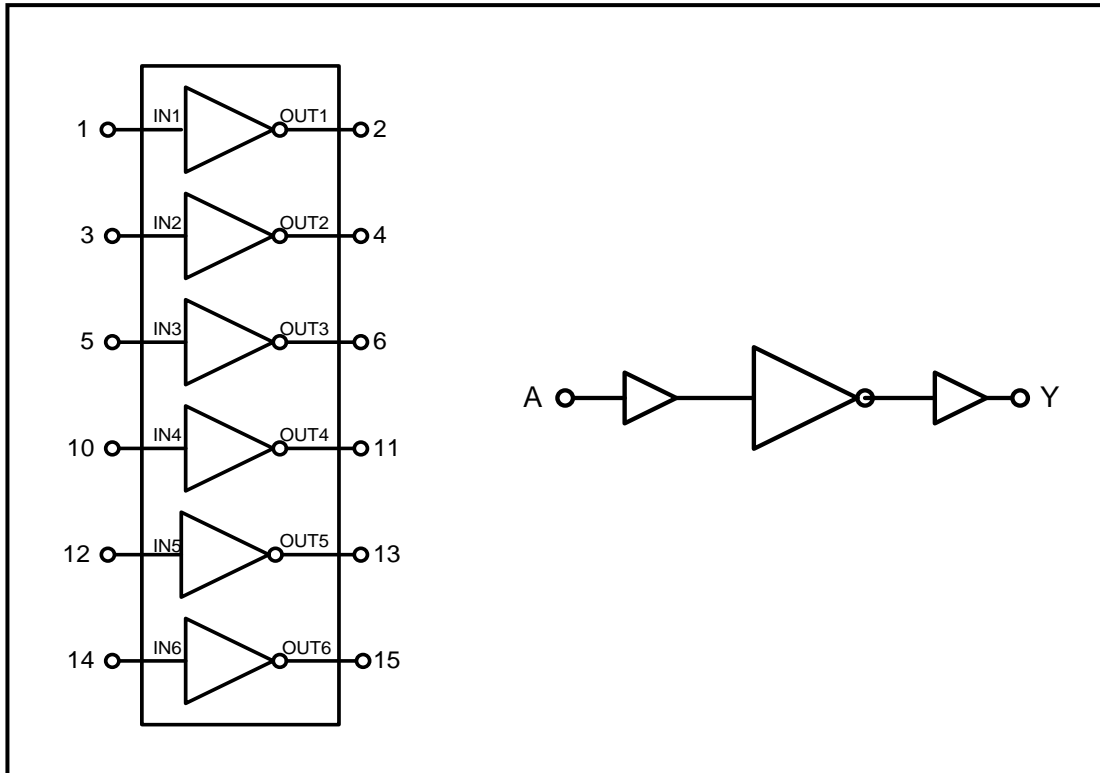

Figure 1. CMT-7404: simplified block diagram.

Absolute Maximum Ratings

Supply Voltage V_{DD} to GND -0.5 to 6.0V
Voltage on any Pin to GND -0.5 to $V_{DD}+0.5V$

Operating Conditions

Supply Voltage V_{DD} to GND 3.3V to 5V ($\pm 10\%$)
Junction temperature -55°C to +175°C

ESD Rating (expected)

Human Body Model 1kV

DC Electrical Characteristics

Unless otherwise stated: $T_j=25^\circ\text{C}$. **Bold underlined** figures indicate values valid over the whole temperature range ($-55^\circ\text{C} < T_j < +175^\circ\text{C}$).

Parameter	Condition	Min	Typ	Max	Units
Supply voltage V_{DD}		3.3	5V		V
Quiescent current I_{DD}	$V_{DD} = 3.3V, T_j = -55^\circ\text{C}$			4	nA
	$V_{DD} = 5V, T_j = -55^\circ\text{C}$			6	
	$V_{DD} = 3.3V, T_j = 175^\circ\text{C}$			<u>928</u>	
	$V_{DD} = 5V, T_j = 175^\circ\text{C}$			<u>229</u>	
Minimum HIGH level output voltage V_{OH}	$V_{DD} = 3.3V, I_{OH} < 2\text{mA}$ (source)	<u>2.46</u>			V
	$V_{DD} = 5V, I_{OH} < 4\text{mA}$ (source)	<u>4.47</u>			
Maximum LOW level output voltage V_{OL}	$V_{DD} = 3.3V, I_{OL} < 2\text{mA}$ (sink)			<u>0.41</u>	V
	$V_{DD} = 5V, I_{OL} < 4\text{mA}$ (sink)			<u>0.59</u>	
Minimum HIGH level input voltage V_{IH}	$V_{DD} = 3.3V$	<u>2.2</u>			V
	$V_{DD} = 5V$	<u>3.3</u>			
Maximum LOW level input voltage V_{IL}	$V_{DD} = 3.3V$			<u>1.5</u>	V
	$V_{DD} = 5V$			<u>2.2</u>	

AC Electrical Characteristics

Unless otherwise stated: VDD=5V, $T_j=25^\circ\text{C}$. **Bold underlined** figures indicate values valid over the whole temperature range ($-55^\circ\text{C} < T_j < +175^\circ\text{C}$).

Parameter	Condition	Temperature	Min	Typ	Max	Units
Propagation delay time from A to Y t_{PHL}	$C_L=50\text{pF}$	$T_j=-55^\circ\text{C}$		7.2	9.5	ns
		$T_j=25^\circ\text{C}$		8.7	11.9	
		$T_j=175^\circ\text{C}$		12	17	
Propagation delay time from A to Y t_{PLH}	$C_L=50\text{pF}$	$T_j=-55^\circ\text{C}$		6.3	8.8	ns
		$T_j=25^\circ\text{C}$		7.9	11.2	
		$T_j=175^\circ\text{C}$		10.8	15.8	
Output transition time High to Low t_{THL}	$C_L=50\text{pF}$	$T_j=-55^\circ\text{C}$		6.6	8.4	ns
		$T_j=25^\circ\text{C}$		8.1	10.7	
		$T_j=175^\circ\text{C}$		11.8	16	
Output transition time Low to High t_{TLH}	$C_L=50\text{pF}$	$T_j=-55^\circ\text{C}$		5.2	7.5	ns
		$T_j=25^\circ\text{C}$		6.9	9.9	
		$T_j=175^\circ\text{C}$		9.8	13.8	

AC Electrical Characteristics (cntd)

Unless otherwise stated: $V_{DD}=3.3V$, $T_j=25^\circ C$. **Bold underlined** figures indicate values valid over the whole temperature range ($-55^\circ C < T_j < +175^\circ C$).

Parameter	Condition	Temperature	Min	Typ	Max	Units
Propagation delay time from A or B to Y t_{PHL}	$C_L=50pF$	$T_j=-55^\circ C$		14	22.1	ns
		$T_j=25^\circ C$		16.5	26.6	
		$T_j=175^\circ C$		21.5	34.4	
Propagation delay time from A or B to Y t_{PLH}	$C_L=50pF$	$T_j=-55^\circ C$		12.3	20.1	ns
		$T_j=25^\circ C$		15	24.4	
		$T_j=175^\circ C$		19.4	31.2	
Output transition time High to Low t_{THL}	$C_L=50pF$	$T_j=-55^\circ C$		10.7	17	ns
		$T_j=25^\circ C$		13	21.5	
		$T_j=175^\circ C$		18	29.5	
Output transition time Low to High t_{TLH}	$C_L=50pF$	$T_j=-55^\circ C$		8	14.3	ns
		$T_j=25^\circ C$		10.2	16.8	
		$T_j=175^\circ C$		13.5	21	

AC Waveforms

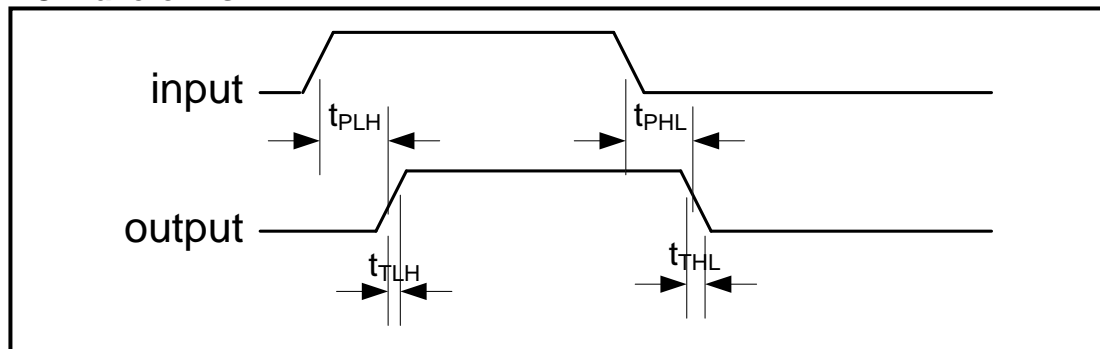
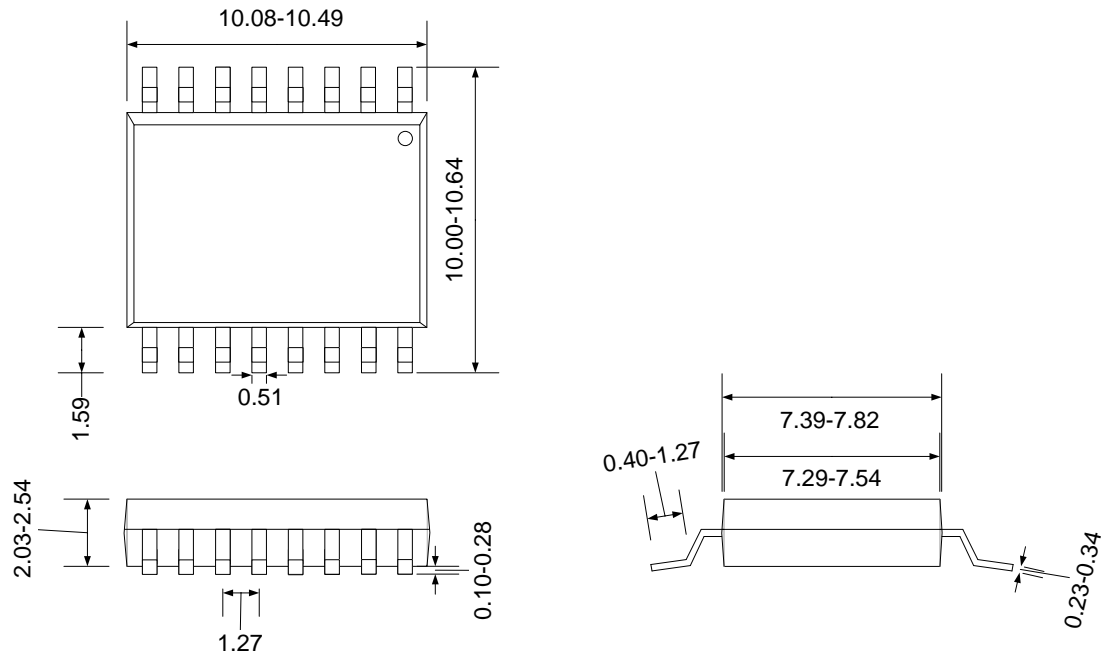

Figure 2. AC Waveforms

Ordering Information

Ordering Reference	Package	Temperature Range	Marking
CMT-7404-PSOIC16-T	Plastic SOIC16	-55°C to +175°C	CMT-7404

Package Dimensions



Drawing PSOIC16 (mm)

Contact & Ordering

CISSOID S.A.

Headquarters and contact EMEA:	CISSOID S.A. – Rue Francqui, 11 – 1435 Mont Saint Guibert - Belgium T : +32 10 48 92 10 - F: +32 10 88 98 75 Email: sales@cissoid.com
Sales Representatives:	Visit our website: http://www.cissoid.com/contact

Disclaimer

Neither CISSOID, nor any of its directors, employees or affiliates make any representations or extend any warranties of any kind, either express or implied, including but not limited to warranties of merchantability, fitness for a particular purpose, and the absence of latent or other defects, whether or not discoverable. In no event shall CISSOID, its directors, employees and affiliates be liable for direct, indirect, special, incidental or consequential damages of any kind arising out of the use of its circuits and their documentation, even if they have been advised of the possibility of such a damage. The circuits are provided "as is". CISSOID has no obligation to provide maintenance, support, updates, or modifications.